



COLDLINE ST 322



**SUTRAK A.Ş.**

**Coldline**

SUTRAK Klima ve Soğutucu Cihazlar İmalat San. ve Tic. A.Ş.

Doğu Sanayi Sitesi 2.Blok No:4 34197 Yenibosna / İSTANBUL/TURKIYE - Phone : +90 212 503 90 57 / 58 - Fax : +90 212 503 89 81

[www.sutrak.com.tr](http://www.sutrak.com.tr) / [info@sutrak.com.tr](mailto:info@sutrak.com.tr)

**MODEL: COLDLINE ST 322**

DESIGNED & PRODUCED BY SÜTRAK A.Ş.

**COLDLINE ST 322**  
(CENTER-DOOR)

FRESH WATER TANK CAPACITY	120 Lt
WASTE WATER TANK CAPACITY	150 Lt
MOTOR FLOW RATE	10,6 L/Min.
PNEUMATIC VALVES	2 Pcs
HANDWASH PUMP	Standard
SOAP DISPENSER	Standard
PAPER TISSUE DISPENSER	Standard
WEIGHT	160 Kg
OPERATING VOLTAGE	24 V DC - 27 V DC
WIDTH	792 mm
LENGTH	1250 mm
HEIGHT	2010 mm
FRESH WATER FLUSH (WF)	Standard
CHEMICAL FLUSH (CF)	Option
DUAL TYPE FLUSH (WF + CF)	Option

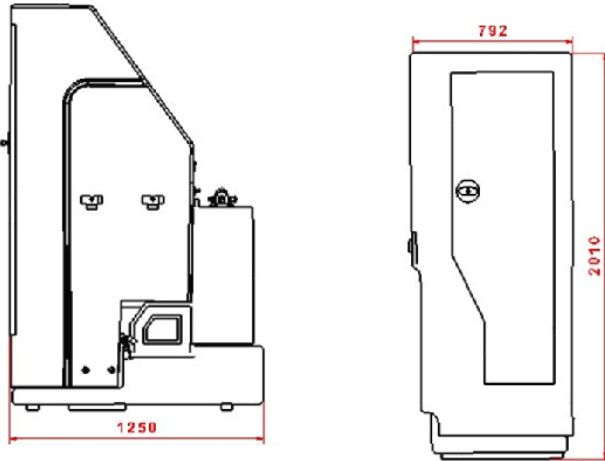

LIGHTWEIGHT



EFFICIENT



**Coldline**