



COLDLINE ST 323



SUTRAK A.Ş.

Coldline

SUTRAK Klima ve Soğutucu Cihazlar İmalat San. ve Tic. A.Ş.

Doğu Sanayi Sitesi 2.Blok No:4 34197 Yenibosna / İSTANBUL/TURKIYE - Phone : +90 212 503 90 57 / 58 - Fax : +90 212 503 89 81

www.sutrak.com.tr / info@sutrak.com.tr

MODEL: COLDLINE ST 323

DESIGNED & PRODUCED BY SÜTRAK A.Ş.

COLDLINE ST 323
(CENTER-DOOR)

| | |
|---------------------------|-------------------|
| FRESH WATER TANK CAPACITY | 35 Lt |
| WASTE WATER TANK CAPACITY | 25 Lt |
| MOTOR FLOW RATE | 10,6 L/Min. |
| PNEUMATIC VALVES | 2 Pcs |
| HANDWASH PUMP | Standard |
| SOAP DISPENSER | Standard |
| PAPER TISSUE DISPENSER | Standard |
| WEIGHT | 140 Kg |
| OPERATING VOLTAGE | 24 V DC - 27 V DC |
| WIDTH | 880 mm |
| LENGTH | 1062 mm |
| HEIGHT | 1876 mm |
| FRESH WATER FLUSH (WF) | Standard |
| CHEMICAL FLUSH (CF) | Option |
| DUAL TYPE FLUSH (WF + CF) | Option |
| FOLDABLE DOOR | Option |

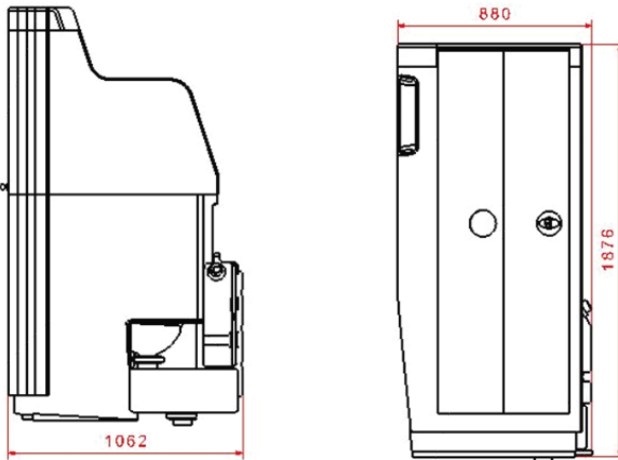

LIGHTWEIGHT



EFFICIENT



Coldline